

PARK MASTER FRONT

09407 - AMF094EUSAA
09417 - KMF094EUSAA

Distributed by



PHONOCAR S.p.a
Via F.lli Cervi, 167/C - 42124 Reggio Emilia (Italy)
Tel. +39 0522 941621 - Fax +39 0522 1602093
e-mail: info@phonocar.it

www.phonocar.com

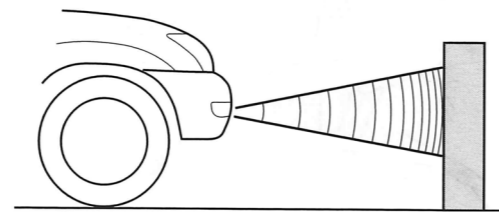

10/2018

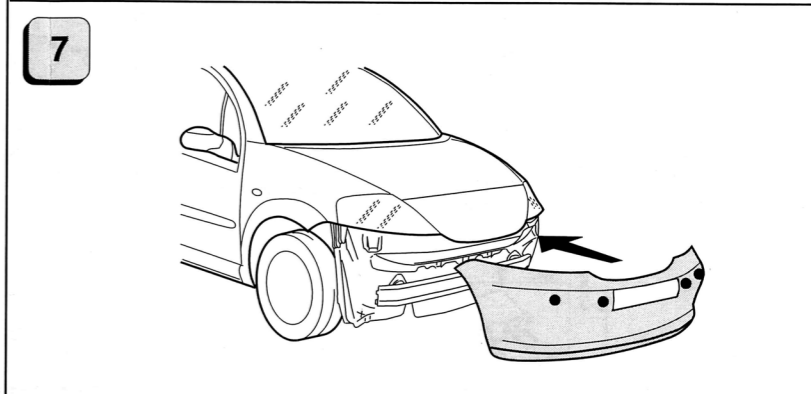
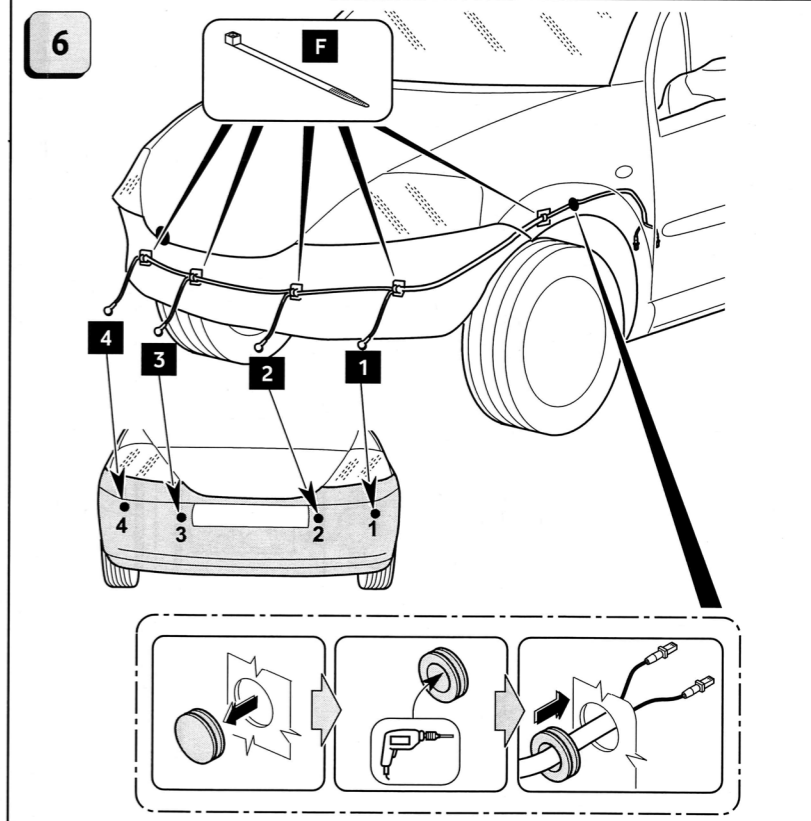
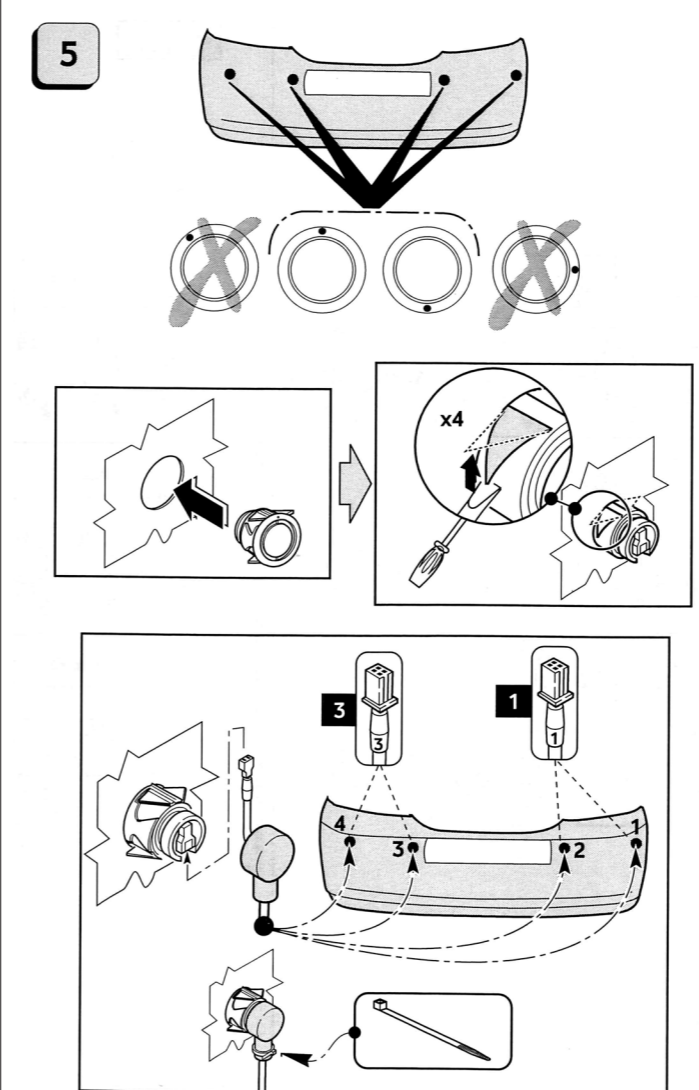
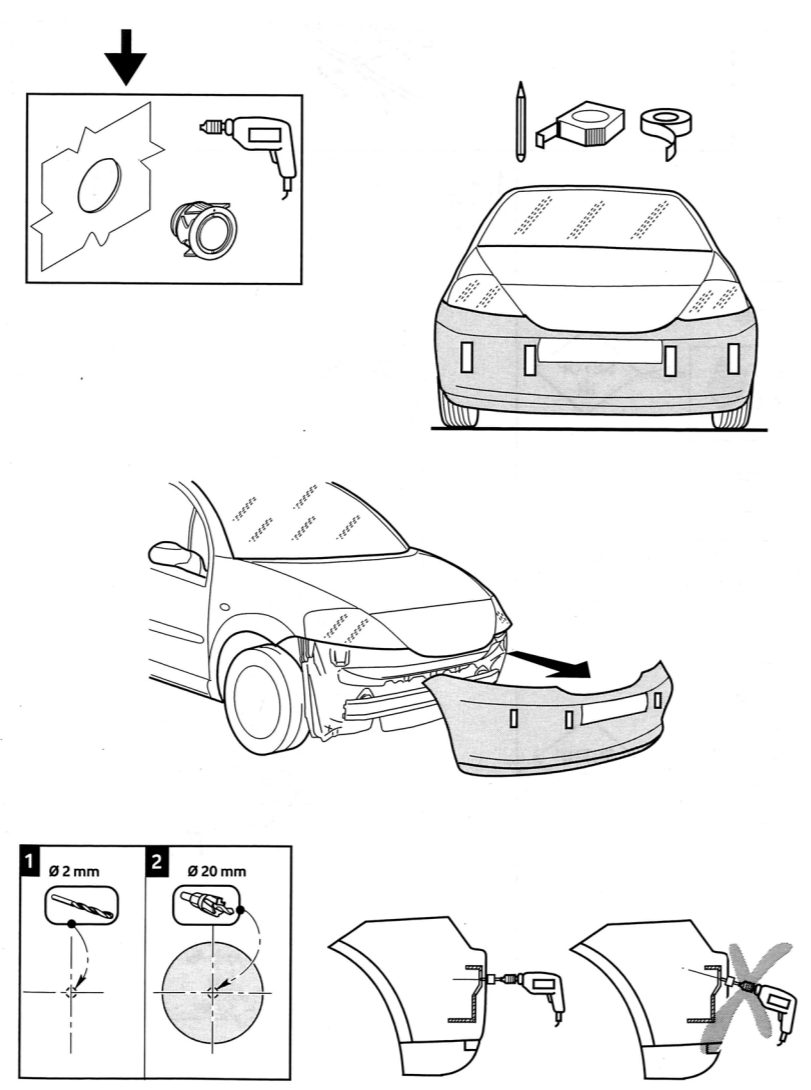
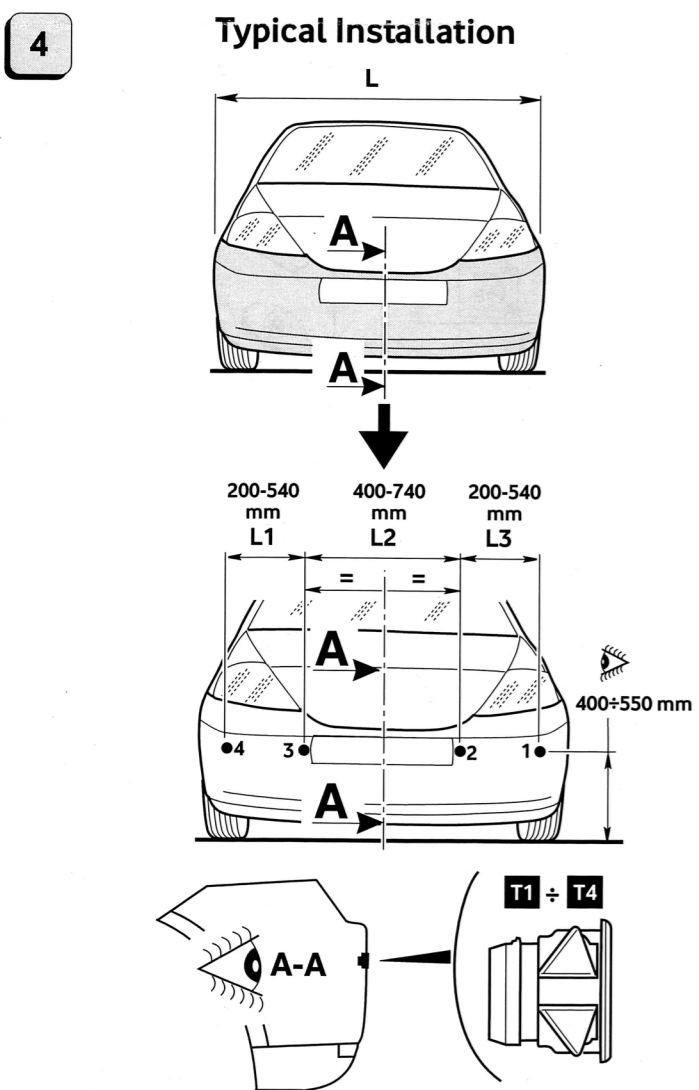
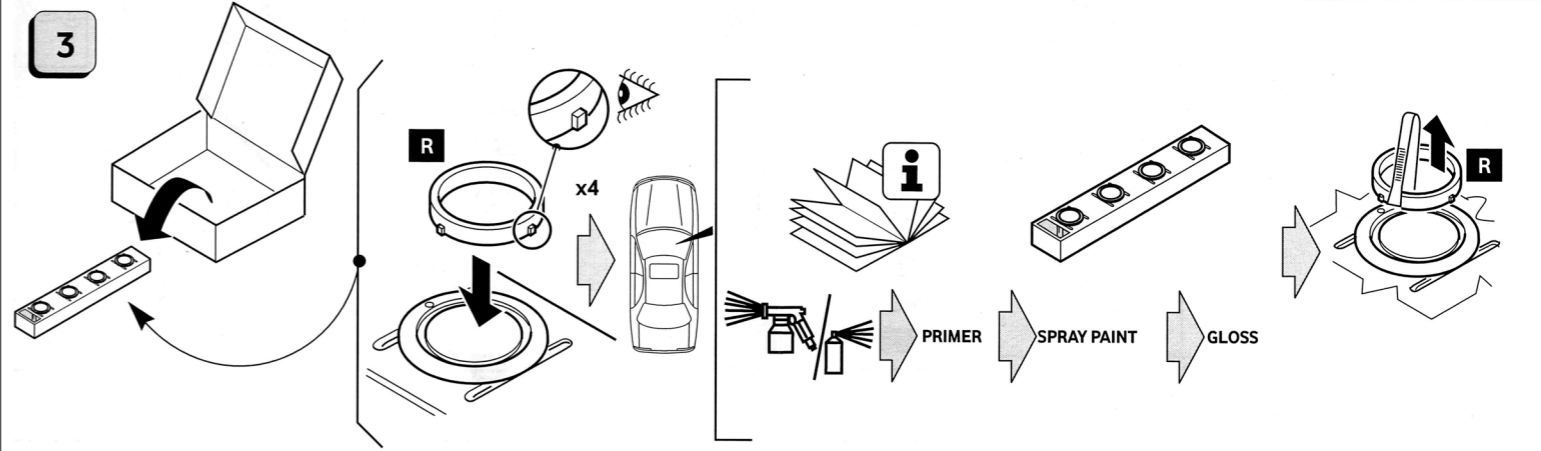
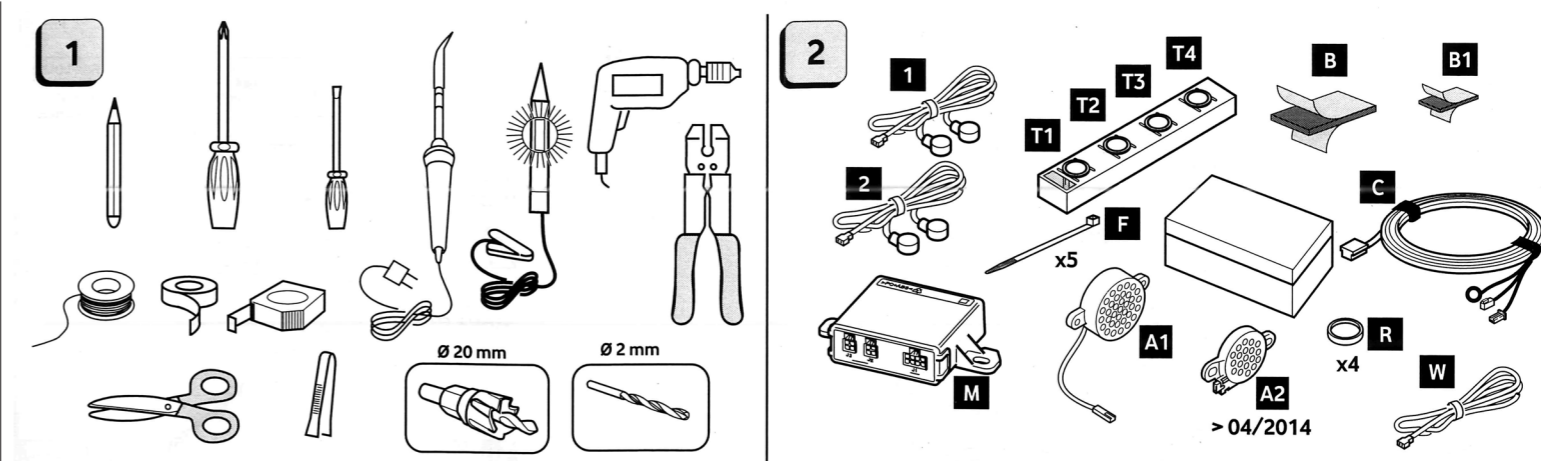

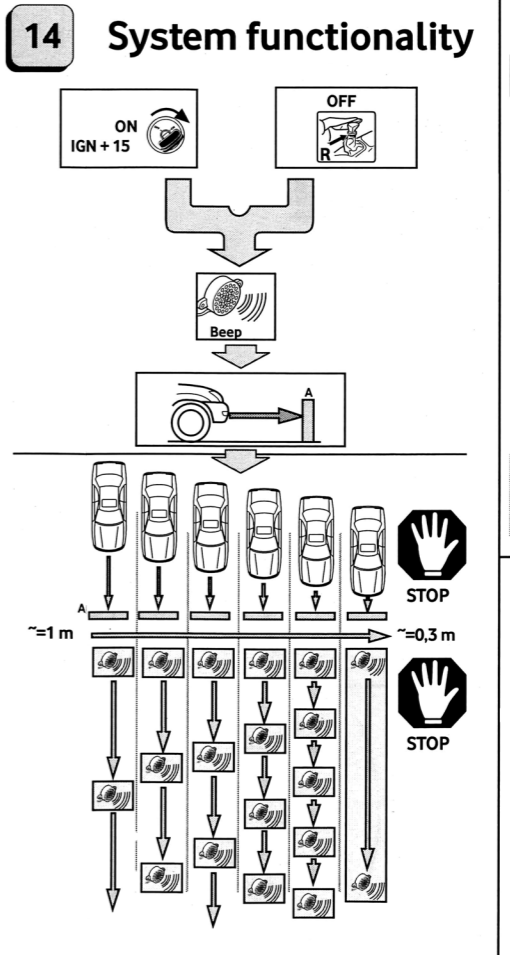
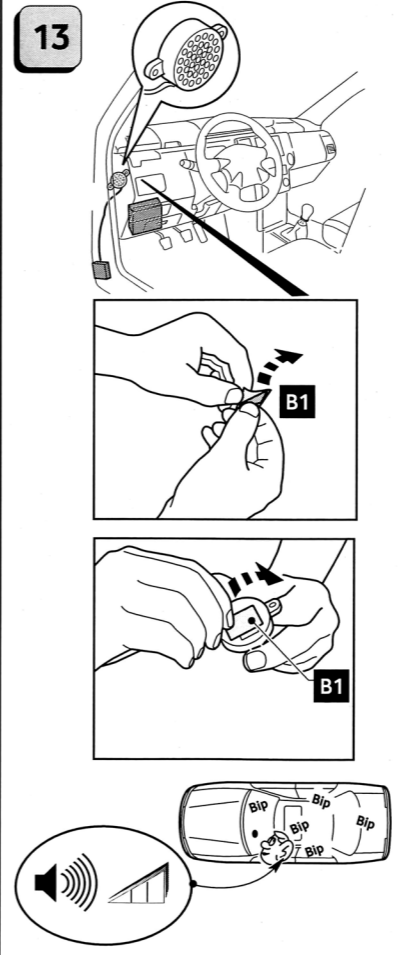
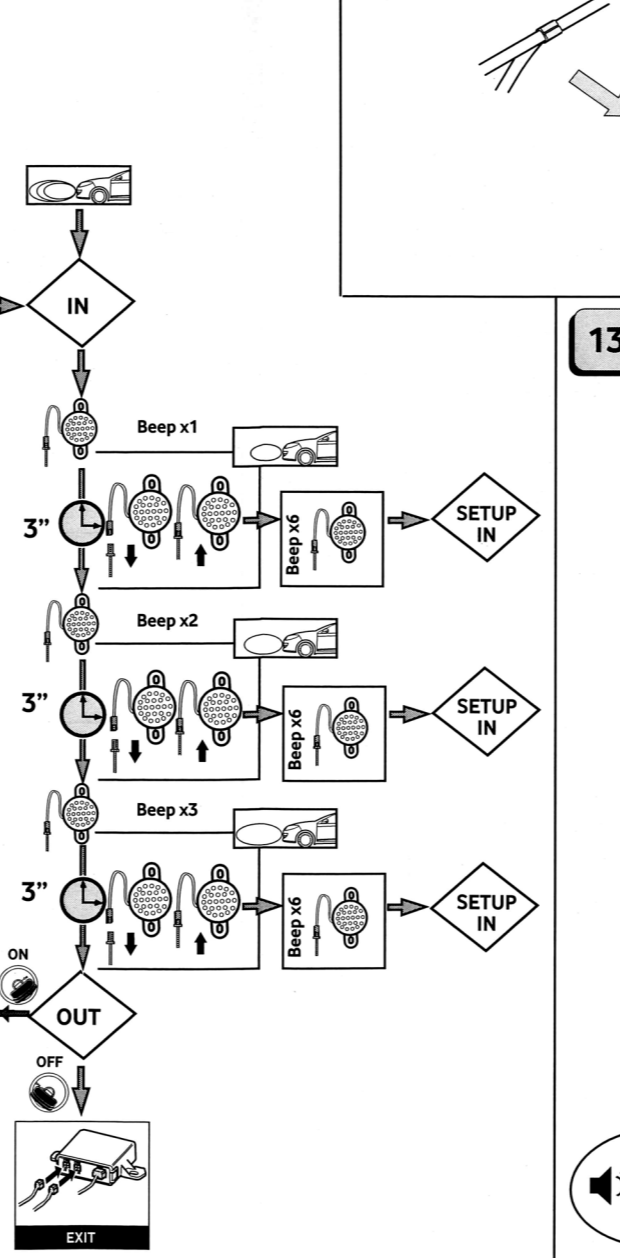
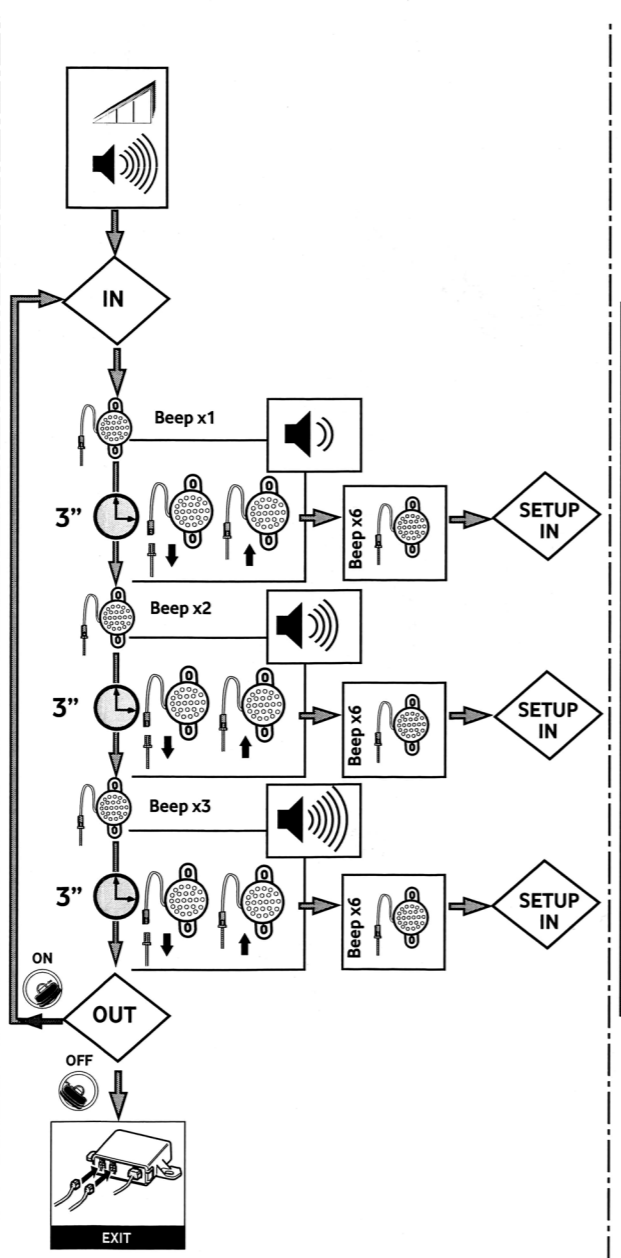
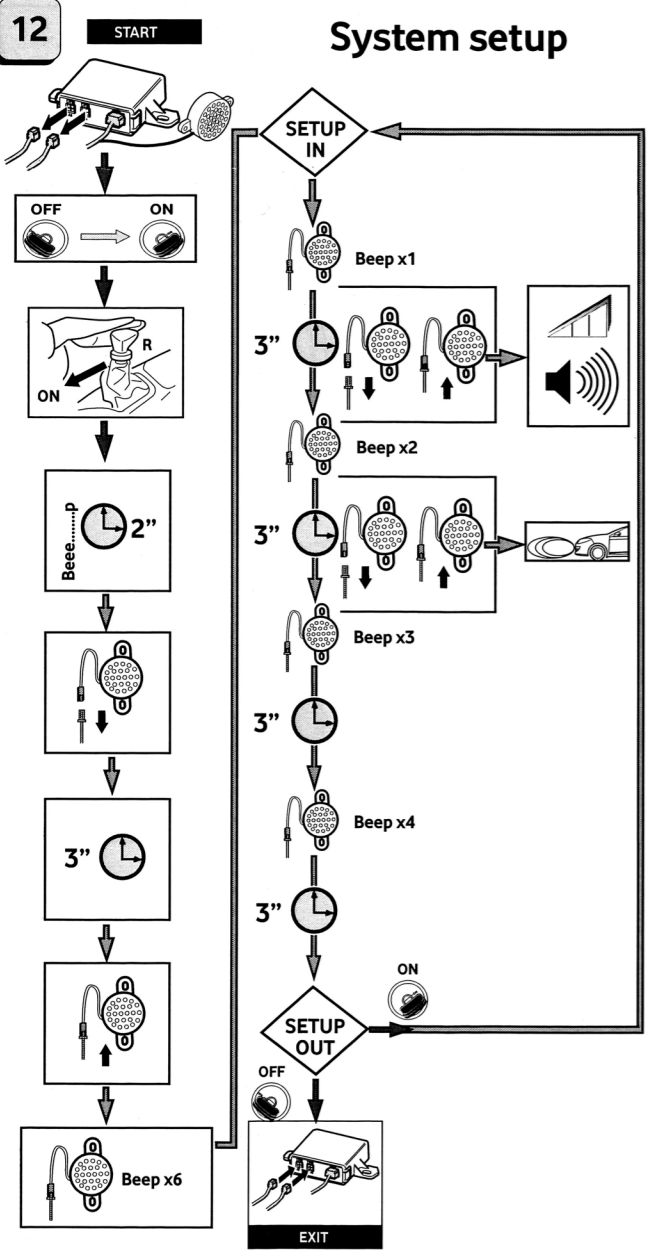
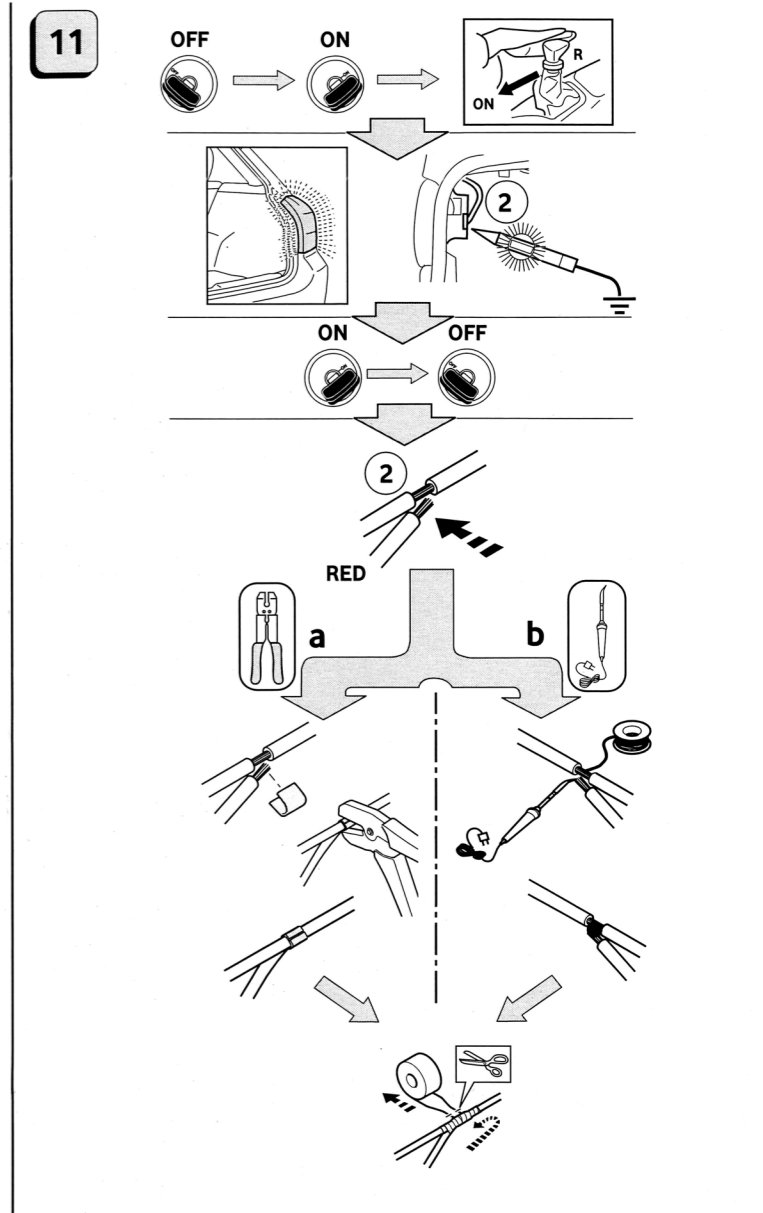
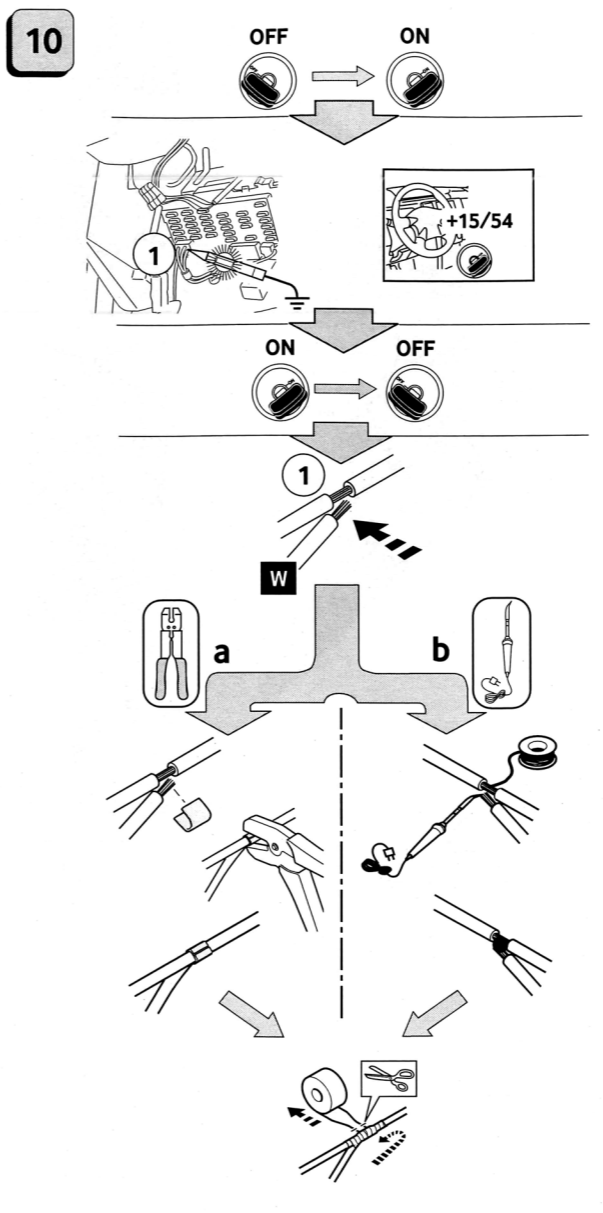
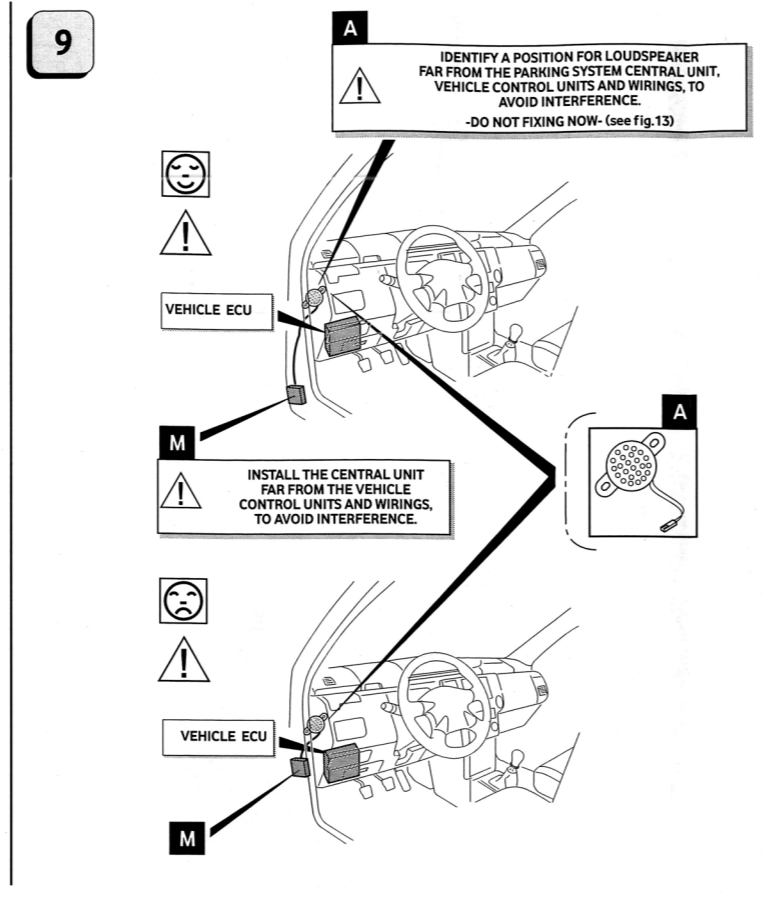
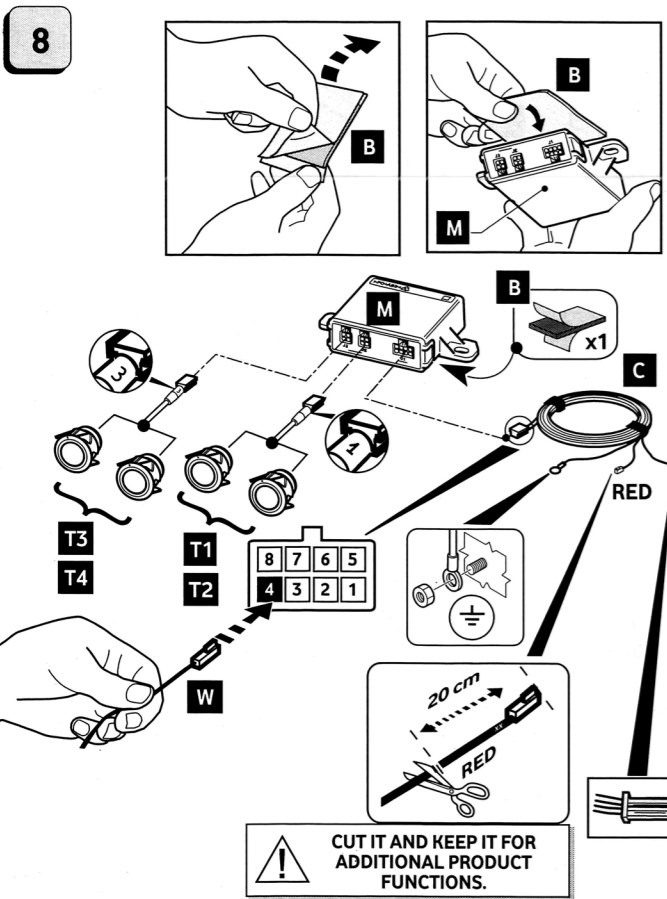

12 VDC.

+15/54

A < 30 mA typ.

-40° C ÷ +85° C

ELECTRICAL/ELECTRONIC SUB-ASSEMBLY WAS APPROVED WITH REGARD TO: E/CE/324-E/CE/TRANS/505 Add.5/Rev.3 Regulation No. 10 UNIFORM PROVISIONS CONCERNING THE APPROVAL OF VEHICLES WITH REGARD TO ELECTROMAGNETIC COMPATIBILITY.

FOR ADDITIONAL FUNCTIONS SEE "INSTALLATION AND CONFIGURATION GUIDE" ON VODAFONE AUTOMOTIVE SITE.